

- DESCRIPTION AND MATERIAL
- Wet Pluggable.
 - Metal to metal key for positive alignment.
 - 316 Stainless Steel passivated per QQ-P-35 Type VI with naval bronze engaging nut.
 - Special alloys are available upon request (contact factory).
 - 10,000 PSI in mated condition.
 - Bulkhead connector design open face pressure rated to 5000 PSI.
 - Contacts gold plated per MIL-G-45204.
 - Engaging nuts have Acme threads for rugged applications and for quick connection.
 - Working voltage for MKS-200/300/3L00/400-BCR/FCR/CCP is 300 VDC.
 - Working voltage for MKS-500/700/900-BCR/FCR/CCP is 600 VDC.
- CABLE
- CCP is not terminated to cable unless specified at the time of order
 - MKS-200/300/3L00/400-BCR/FCR has Type E leads per MIL 16878/4.
 - MKS-500/700/900-BCR/FCR has Type EE leads per MIL 16878/5.
- USES
- Light and Heavy Duty applications.
 - Hazardous environment.
 - Power Transmission.
 - Signal Telemetry.
 - ROV applications.
- GUIDELINES
- All mounting and sealing surfaces require a 32 finish.
 - Lubricate mating surfaces with 3M Silicone Spray or equivalent, DO NOT grease! Connectors must be lubricated on a regular basis.
 - Lubricate o-rings with Dow Corning #111 Valve Lubricant or equivalent.
 - Use Dust Caps and keep connectors clean to prevent damage in storage and service.
 - Keep o-ring grooves clean and avoid cuts, nicks and tears on rubber surfaces.
 - Elastomers can be seriously degraded if exposed to direct sunlight or high ozone levels for extended periods of time.
 - Clean plugs and receptacles with soap and fresh water. Rinse out with alcohol, allowing connector to air dry.
 - Replace o-rings when re-using connectors.

MKS(W)-9

METAL KEY WET PLUGGABLE RUBBER MOLDED TITAN™ SERIES

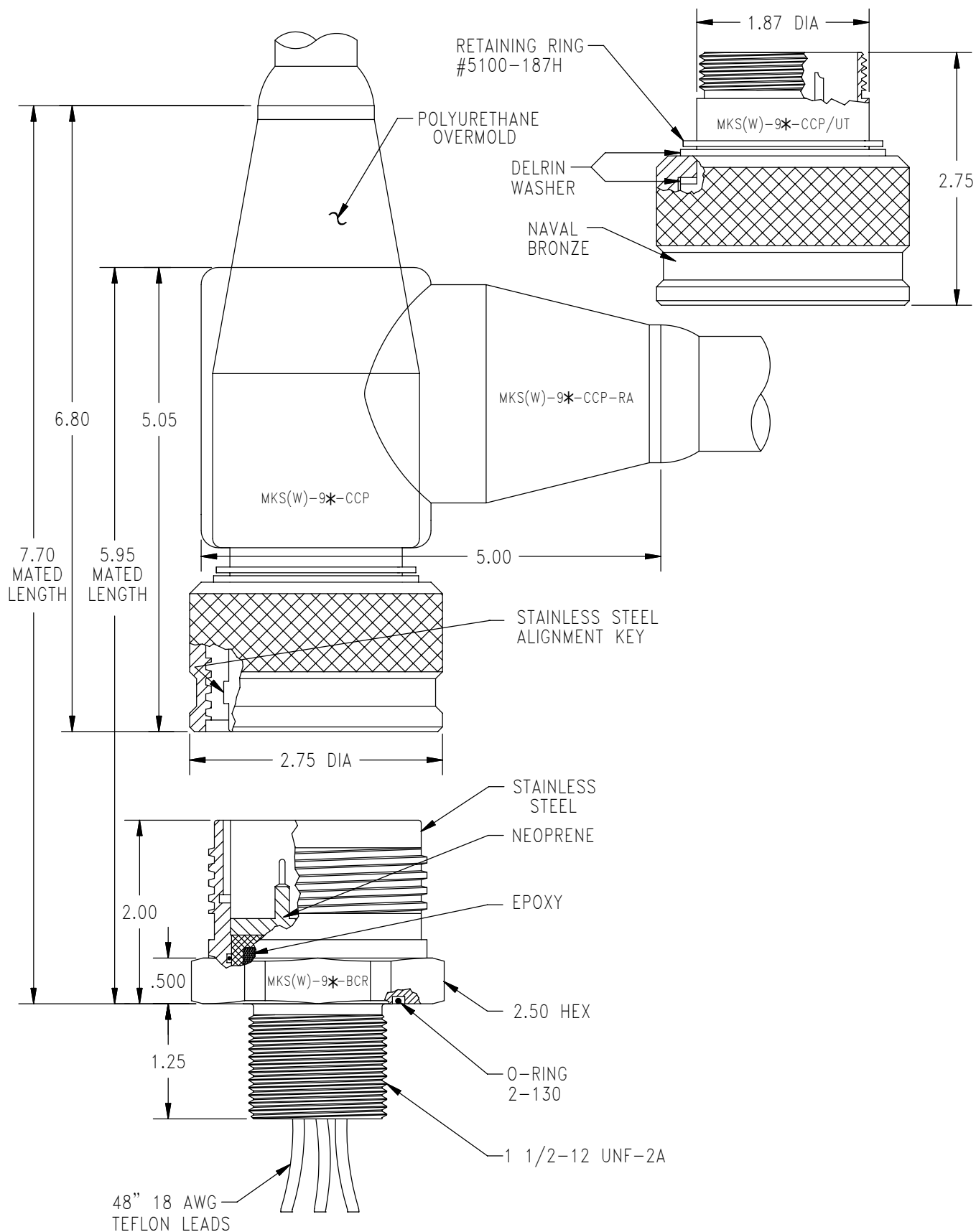

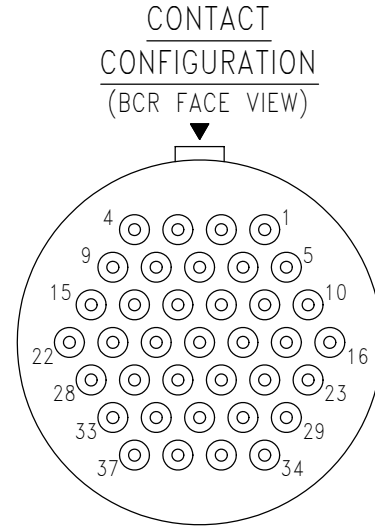
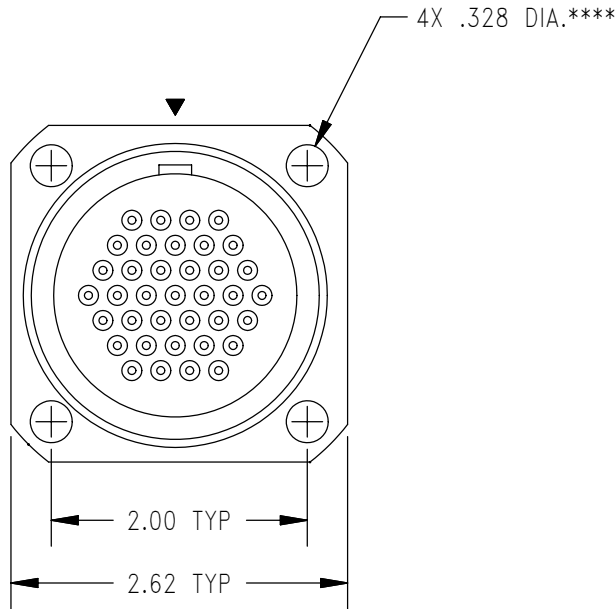

37#16

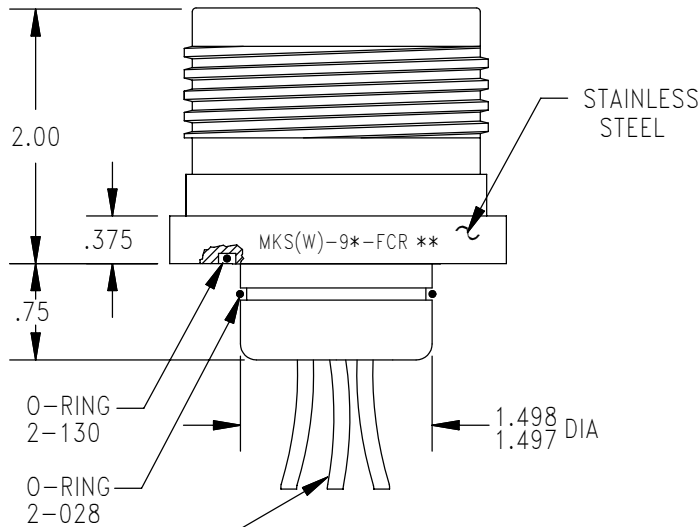

48" 18 AWG
TEFLON LEADS

MOUNTING INSTRUCTIONS

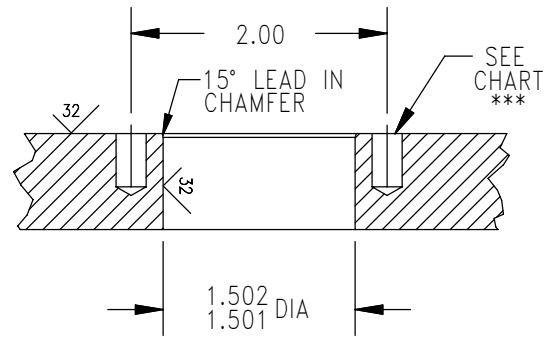

MOUNTING TORQUE FOR BCR	not to exceed 335 in lbs	MATED PRESSURE RATING (psi)	10,000
See pg. 9580 for SCP/SCR information.			
<p>NOTE: CCP is not terminated to cable unless specified.</p> <p>* Please specify number of contacts.</p> <p>** Internal assembly same as MKS(W)-9*-BCR (facing page).</p> <p>*** Blind tapped hole not to penetrate bulkhead, minimum full thread depth 2 times bolt diameter.</p> <p>**** Modified M8 socket head cap bolts are available.</p>			