

- DESCRIPTION AND MATERIAL
- Wet Pluggable.
 - Metal to metal key for positive alignment.
 - 316 Stainless Steel passivated per QQ-P-35 Type VI with naval bronze engaging nut.
 - Special alloys are available upon request (contact factory).
 - 10,000 PSI in mated condition.
 - Bulkhead connector design open face pressure rated to 5000 PSI.
 - Contacts gold plated per MIL-G-45204.
 - Engaging nuts have Acme threads for rugged applications and for quick connection.
 - Working voltage – 600 VDC
- CABLE
- CCP is not terminated to cable unless specified at the time of order
 - BCR has teflon leads, Type E per MIL 16878/4
- USES
- Light and Heavy Duty applications.
 - Hazardous environment.
 - Power Transmission.
 - Signal Telemetry.
 - ROV applications.
- GUIDELINES
- All mounting and sealing surfaces require a 32 finish.
 - Lubricate mating surfaces with 3M Silicone Spray or equivalent, DO NOT grease! Connectors must be lubricated on a regular basis.
 - Lubricate o-rings with Dow Corning #111 Valve Lubricant or equivalent.
 - Use Dust Caps and keep connectors clean to prevent damage in storage and service.
 - Keep o-ring grooves clean and avoid cuts, nicks and tears on rubber surfaces.
 - Elastomers can be seriously degraded if exposed to direct sunlight or high ozone levels for extended periods of time.
 - Clean plugs and receptacles with soap and fresh water. Rinse out with alcohol, allowing connector to air dry.
 - Replace o-rings when re-using connectors.

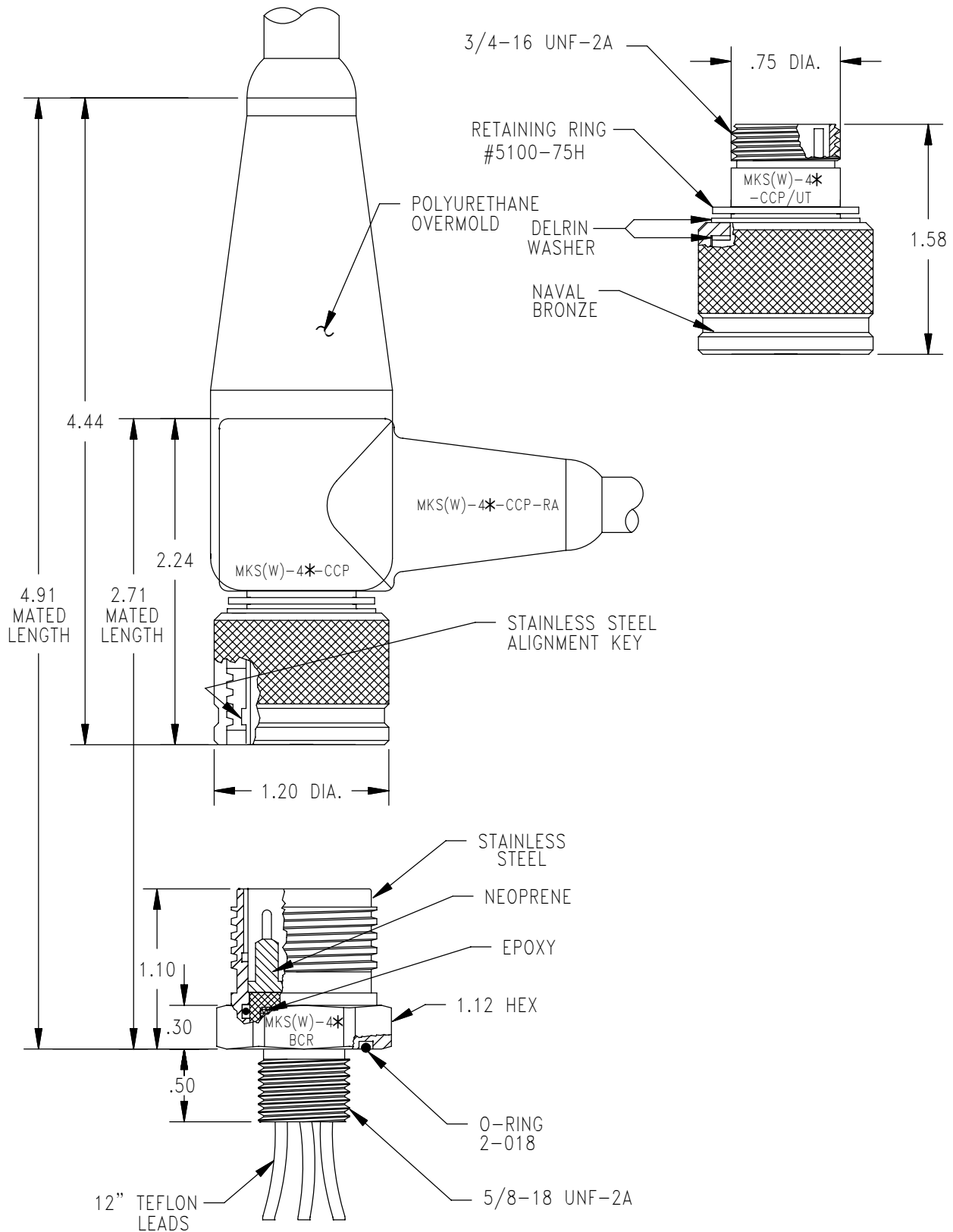

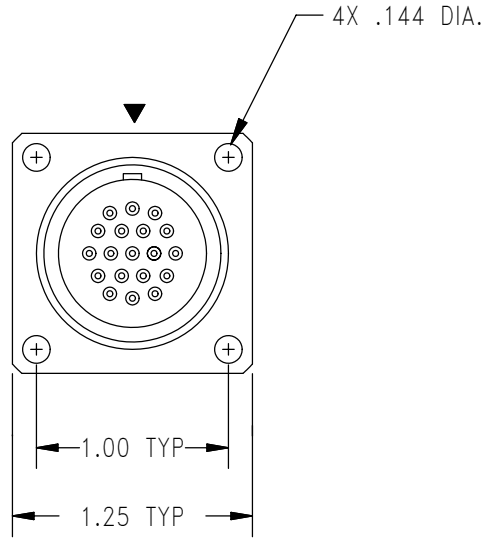

CONTACT
CONFIGURATION
(BCR FACE VIEW)

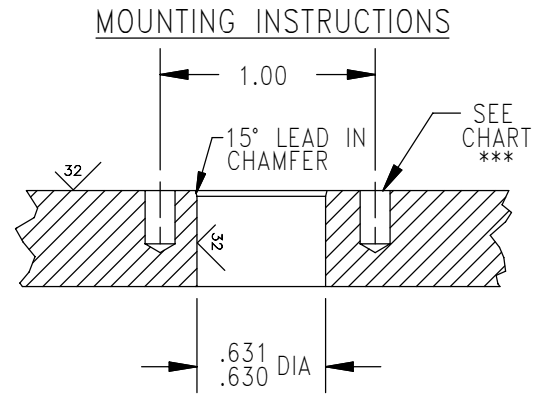
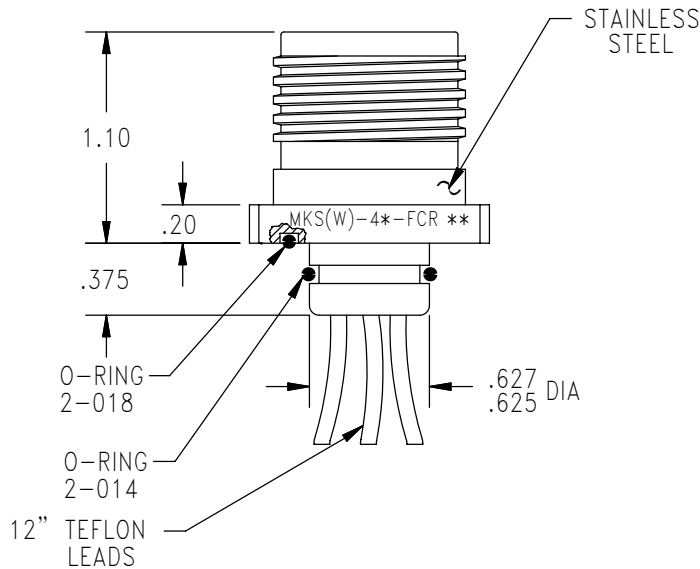
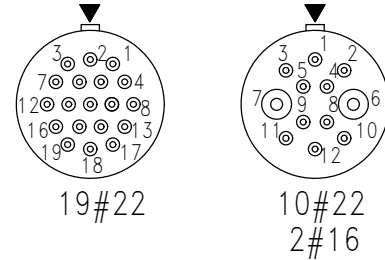

MOUNTING TORQUE FOR BCR	not to exceed 100 in lbs	MATED PRESSURE RATING (psi)	10,000
-------------------------	--------------------------	-----------------------------	--------

See pg. 9580 for SCP/SCR information.

NOTE: CCP is not terminated to cable unless specified.

* Please specify number of contacts.

** Internal assembly same as MKS(W)-4*-BCR (facing page).

*** Blind tapped hole not to penetrate bulkhead, minimum full thread depth 2 times bolt diameter.