

-
- DESCRIPTION AND MATERIAL
- Metal to metal key for positive alignment.
 - 316 Stainless Steel passivated per QQ-P-35 Type VI with naval bronze engaging nut.
 - Special alloys are available upon request (contact factory).
 - 10,000 PSI in mated condition.
 - Bulkhead connector design open face pressure rated to 5000 PSI.
 - Contacts gold plated per MIL-G-45204.
 - Engaging nuts have Acme threads for rugged applications and for quick connection.
 - Working voltage – 300 VDC
- CABLE
- CCP is not terminated to cable unless specified at the time of order
 - BCR has teflon leads, Type E per MIL 16878/4
- USES
- Light and Heavy Duty applications.
 - Hazardous environment.
 - Power Transmission.
 - Signal Telemetry.
 - ROV applications.
- GUIDELINES
- All mounting and sealing surfaces require a 32 finish.
 - Lubricate mating surfaces with 3M Silicone Spray or equivalent, DO NOT grease! Connectors must be lubricated on a regular basis.
 - Lubricate o-rings with Dow Corning #111 Valve Lubricant or equivalent.
 - Use Dust Caps and keep connectors clean to prevent damage in storage and service.
 - Keep o-ring grooves clean and avoid cuts, nicks and tears on rubber surfaces.
 - Elastomers can be seriously degraded if exposed to direct sunlight or high ozone levels for extended periods of time.
 - Clean plugs and receptacles with soap and fresh water. Rinse out with alcohol, allowing connector to air dry.
 - Replace o-rings when re-using connectors.
- NOTES
- See Page 95 40 for Metal Key Wet Pluggable specifications

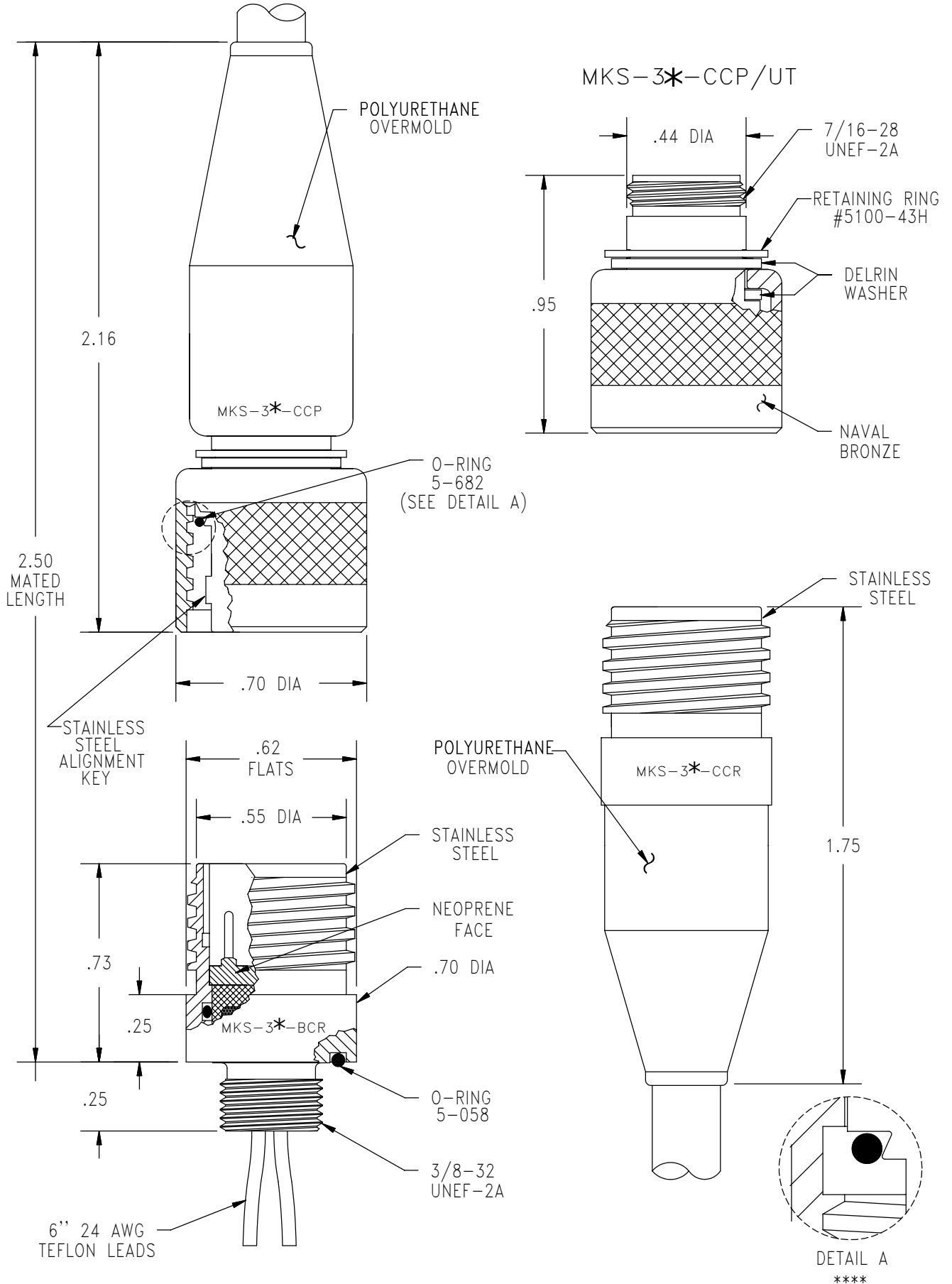

CONTACT CONFIGURATION
(BCR FACE VIEW)

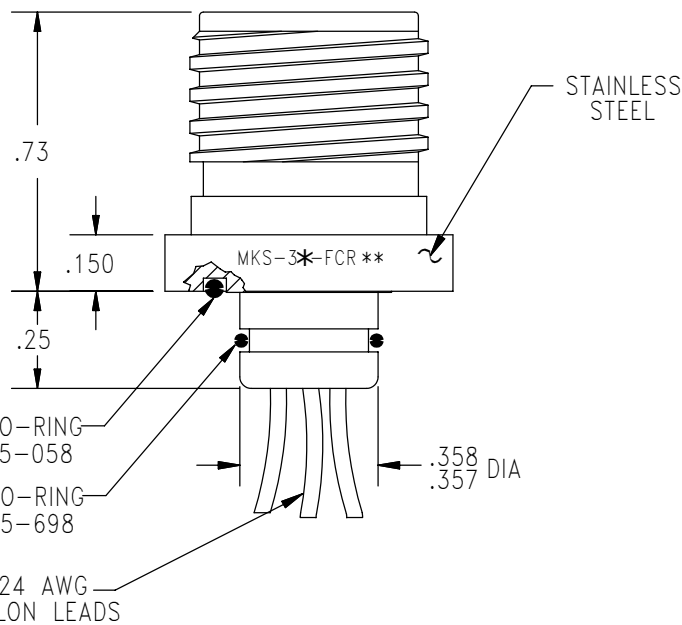
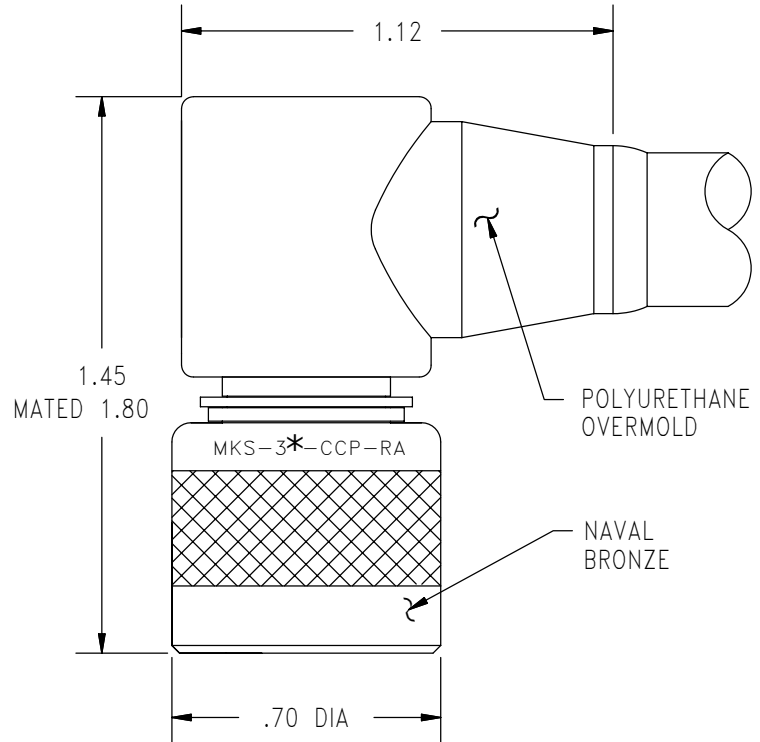
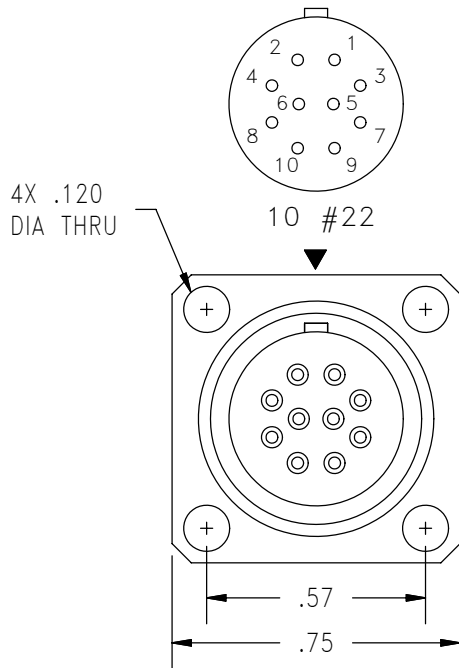

MOUNTING INSTRUCTIONS

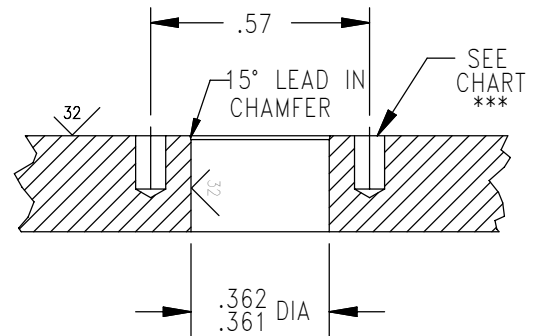

MOUNTING TORQUE FOR BCR	not to exceed 50 in lbs	MATED PRESSURE RATING (psi)	10,000
-------------------------	-------------------------	-----------------------------	--------

See pg. 9580 for SCP/SCR information.

NOTE: CCP is not terminated to cable unless specified.

* Please specify number of contacts.

** Internal assembly same as MKS-3*-BCR (facing page).

*** Blind tapped hole not to penetrate bulkhead, minimum full thread depth 2 times bolt diameter.

**** O-Ring installation tool available – Contact factory for further details.