

- DESCRIPTION AND MATERIAL
- 316 stainless steel passivated per QQ-P-35 Type VI with naval bronze engaging nut.
 - Special alloys are available upon request (contact factory).
 - Contains a removable glass reinforced epoxy insert.
 - Up to 61 contacts.
 - Up to 600 VDC.
 - 10,000 PSI in mated condition (higher pressure rating available using special alloy metal shell; please contact factory).
 - Bulkhead connector design open face pressure rated to 5,000 psi.
 - MHD-CCR/CCP connectors can be overmolded with polyurethane.
 - Contacts are gold plated per MIL-G-45204.
- CABLE
- Connector's amperage and voltage may be limited by the amperage and voltage ratings of the cable to which the connector is molded.
 - This series is not molded to cable unless specified at the time of order.
- USES
- Signal telemetry.
 - Hazardous environment.
 - FCR is mounted by use of four equally spaced bolts around the flange surface.
 - FCR is used in place of the BCR when the use of a bulkhead nut and washer is impractical.
 - For all open face pressures above 5,000 PSI the BCR, FCR must be back potted (please contact the factory).
 - The CCR is used in a variety of environments where cable to cable termination is necessary.
- GUIDELINES
- Mounting torque should not exceed 150 in/lbs. for this series.
 - All mounting surfaces require a 32 finish.
 - Align indexes.
 - Keep o-ring grooves clean.
 - Avoid o-ring cuts and nicks.
 - Lubricate o-rings with Dow Corning #111 Valve Lubricant or equivalent.
 - Replace o-rings when re-using connectors.
 - Avoid contact with noxious solvents.
 - Elastomers can be seriously degraded if exposed to direct sunlight or high ozone levels for extended periods of time.

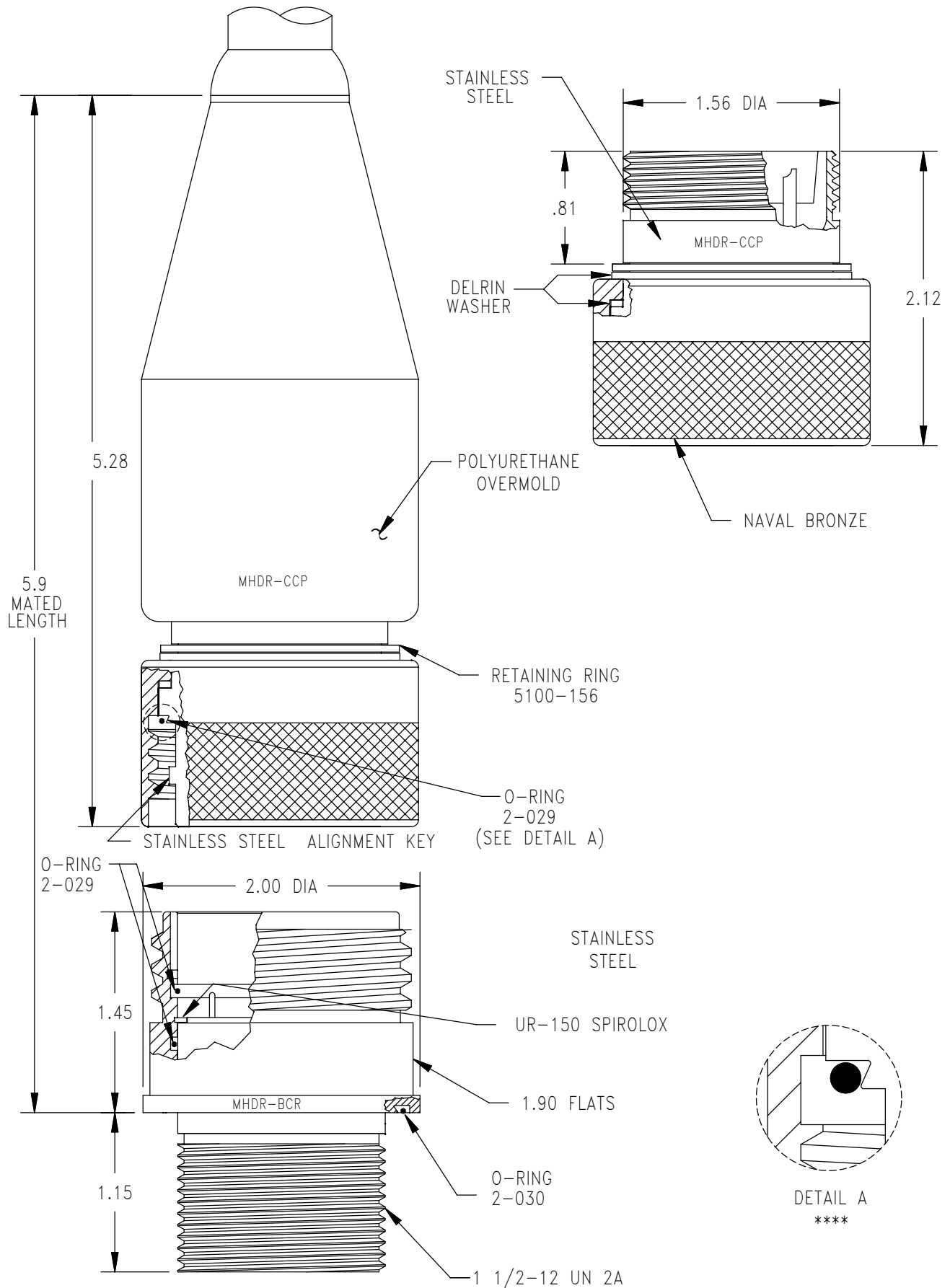

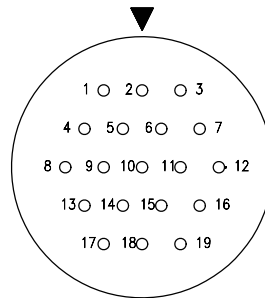

600VDC

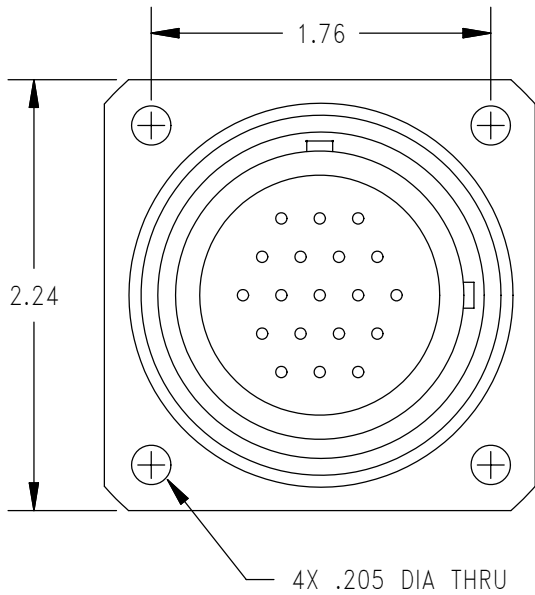
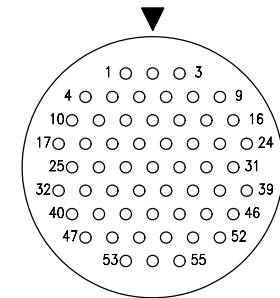

600VDC

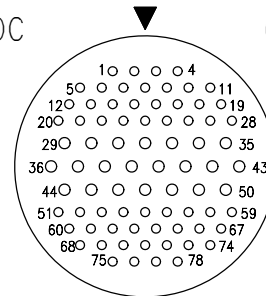

56#22
600VDC

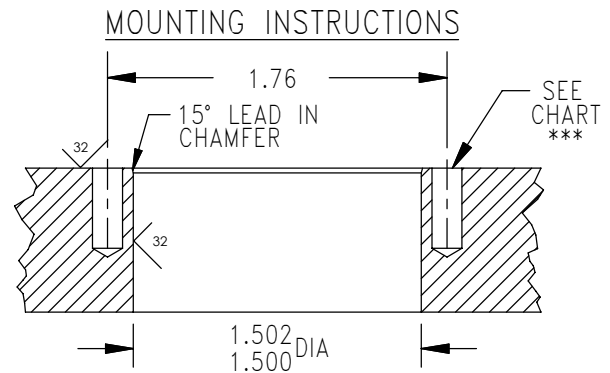
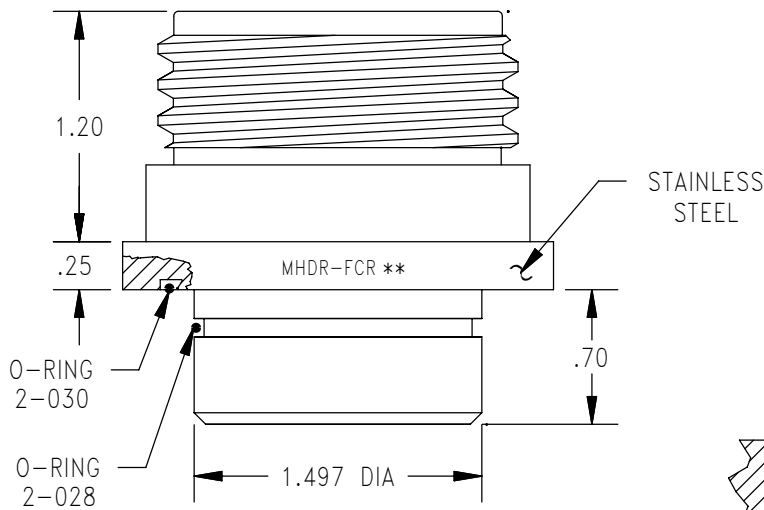

MOUNTING TORQUE FOR MHDR-BCR	not to exceed 200 in lbs	MATED PRESSURE RATING (psi)	10,000
DUMMY PLUG FOR MHDR-BCR/FCR/CCR	MHDR-SCP	DUMMY PLUG FOR MHDR-CCP	MHDR-SCR

NOTE: CCP is not terminated to cable unless specified.

* Please specify number of contacts.

** Internal assembly same as MHDR-BCR (facing page).

*** Blind tapped hole not to penetrate bulkhead, minimum full thread depth 2 times bolt diameter.

**** O-Ring installation tool available - Contact factory for further details.