

## MINIATURE HIGH DENSITY SERIES

---

- DESCRIPTION AND MATERIAL
- 316 stainless steel passivated per QQ-P-35 Type VI with naval bronze engaging nut.
  - Special alloys are available upon request (contact factory).
  - Contains a removable glass reinforced epoxy insert. (Except for MHDG series and CCP's)
  - Up to 61 contacts.
  - Up to 600 VDC.
  - 10,000 PSI in mated condition (higher pressure rating available using special alloy metal shell; please contact factory).
  - Bulkhead connector design open face pressure rated to 5,000 psi.
  - MHD-CCR/CCP connectors can be overmolded with polyurethane.
  - Contacts are gold plated per MIL-G-45204.
- CABLE
- Connector's amperage and voltage may be limited by the amperage and voltage ratings of the cable to which the connector is molded.
  - This series is not molded to cable unless specified at the time of order.
- USES
- Signal telemetry.
  - Hazardous environment.
  - FCR is mounted by use of four equally spaced bolts around the flange surface.
  - FCR is used in place of the BCR when the use of a bulkhead nut and washer is impractical.
  - For all open face pressures above 5,000 PSI the BCR, FCR must be back potted (please contact the factory).
  - The CCR is used in a variety of environments where cable to cable termination is necessary.
- GUIDELINES
- Mounting torque should not exceed 150 in lbs. for this series.
  - All mounting surfaces require a 32 finish.
  - Align indexes.
  - Keep o-ring grooves clean.
  - Avoid o-ring cuts and nicks.
  - Lubricate o-rings with Dow Corning #111 Valve Lubricant or equivalent.
  - Replace o-rings when re-using connectors.
  - Avoid contact with noxious solvents.
  - Elastomers can be seriously degraded if exposed to direct sunlight or high ozone levels for extended periods of time.

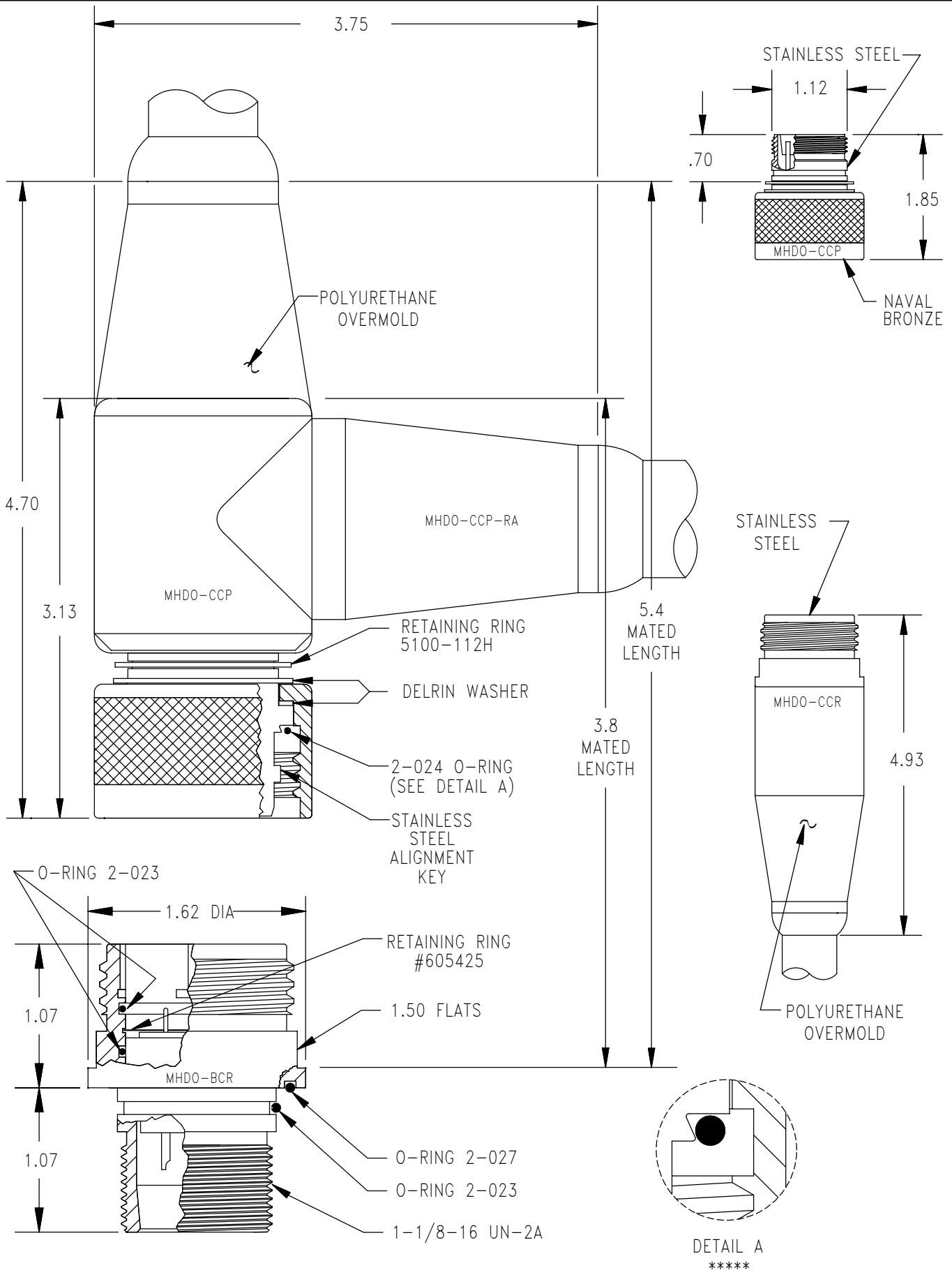

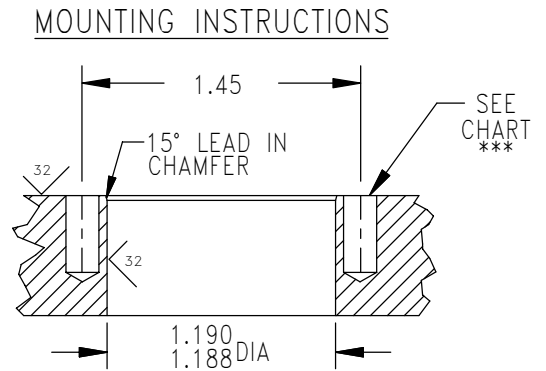
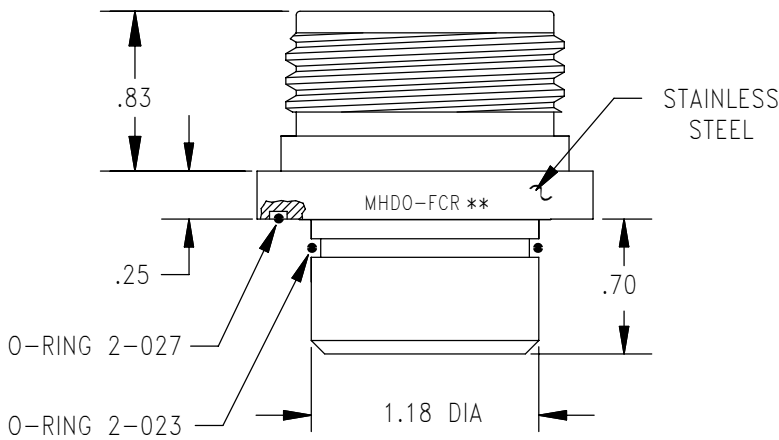
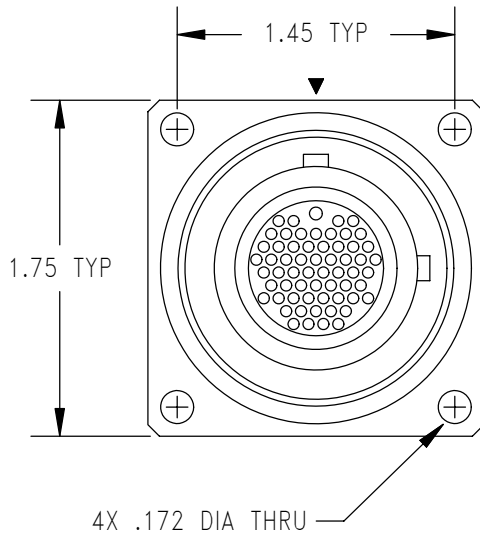

MOUNTING TORQUE FOR MHDO-BCR	not to exceed 200 in lbs	MATED PRESSURE RATING (psi)	10,000
DUMMY PLUG FOR MHDO-BCR/FCR/CCR	MHDO-SCP	DUMMY PLUG FOR MHDO-CCP	MHDO-SCR

NOTE: CCP and CCR are not terminated to cable unless specified.

\* Please specify number of contacts.

\*\* Internal assembly same as MHDO-BCR (facing page).

\*\*\* Blind tapped hole not to penetrate bulkhead, minimum full thread depth 2 times bolt diameter.

\*\*\*\* Oil filled version available. See section 86.

\*\*\*\*\* O-Ring installation tool available – Contact factory for further details.

CONTACT  
CONFIGURATION  
(BCR FACE VIEW)

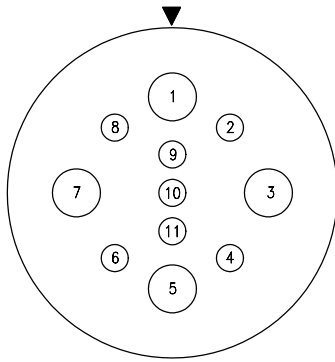

7#22  
4#10  
600VDC

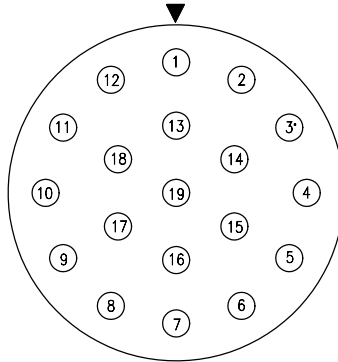

19#16  
600VDC

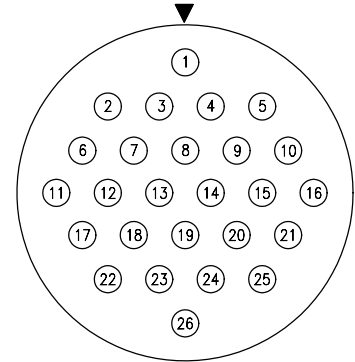

26#20  
450VDC

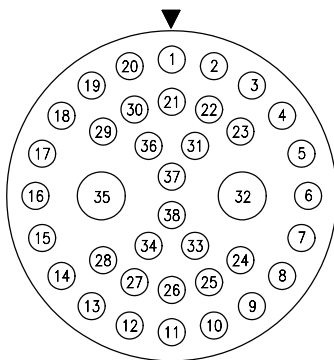

2#10  
36#22  
300VDC

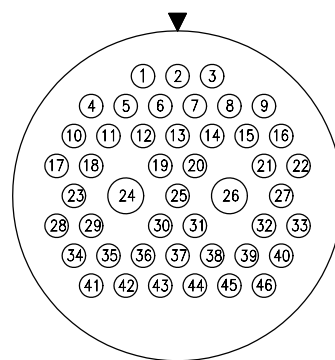

44#22  
2#16  
300VDC

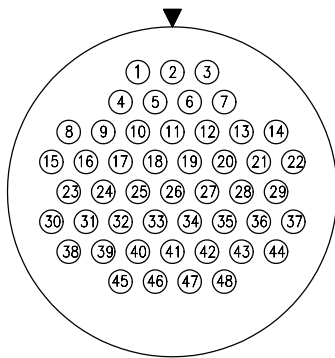

48#22  
300VDC

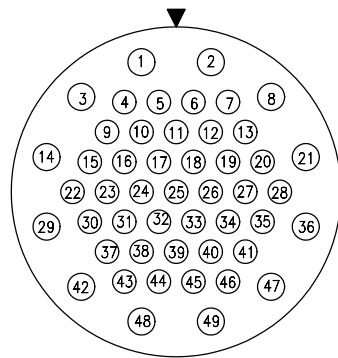

12#20  
37#22  
300VDC

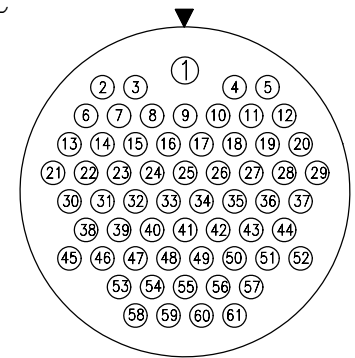

1#20  
60#22  
300VDC