

- DESCRIPTION AND MATERIAL
- Body and engaging nut are 316 Stainless Steel, passivated per QQ-P-35 Type VI.
 - To 10,000 PSI in mated condition.
 - Bulkhead connector design open face pressure rated to 5,000 PSI.
 - Contacts gold plated per MIL-G-45204.
 - Engaging nuts have Acme threads for rugged applications and a quick connection.
 - Working voltage – 850 VDC (Contact factory for high voltage applications.)
 - Bulkhead has sockets, cable connector plug has pins.
- CABLE
- CCP, CCP-R/A and CCR are molded on standard 24” 16 AWG SO cable.
 - Other cable options available at customer’s request.
 - BCR/FCR on standard 48” teflon leads, Type E per MIL 16878/4 16 AWG.
 - Un-Terminated versions of CCP available.
- USES
- Heavy Duty applications.
 - Hazardous environment.
 - Power Transmission.
 - Signal Telemetry.
 - ROV applications.
- GUIDELINES
- All mounting and sealing surfaces require a 32 finish.
 - Lubricate mating surfaces with 3M Silicone spray or equivalent, DO NOT grease! Connectors must be lubricated on a regular basis.
 - Lubricate o-rings with Dow Corning #111 Valve Lubricant or equivalent.
 - Use Dust Caps and keep connectors clean to prevent damage in storage and service.
 - Keep o-ring grooves clean and avoid cuts, nicks and tears on rubber surfaces.
 - Elastomers can be seriously degraded if exposed to direct sunlight or high ozone levels for extended periods of time.
 - Clean plugs and receptacles with soap and fresh water. Rinse out with alcohol, allowing connector to air dry.
 - Replace o-rings when re-using connectors.

IE55V-20

IE55V INVERTED RUBBER MOLDED METAL SHELL SERIES

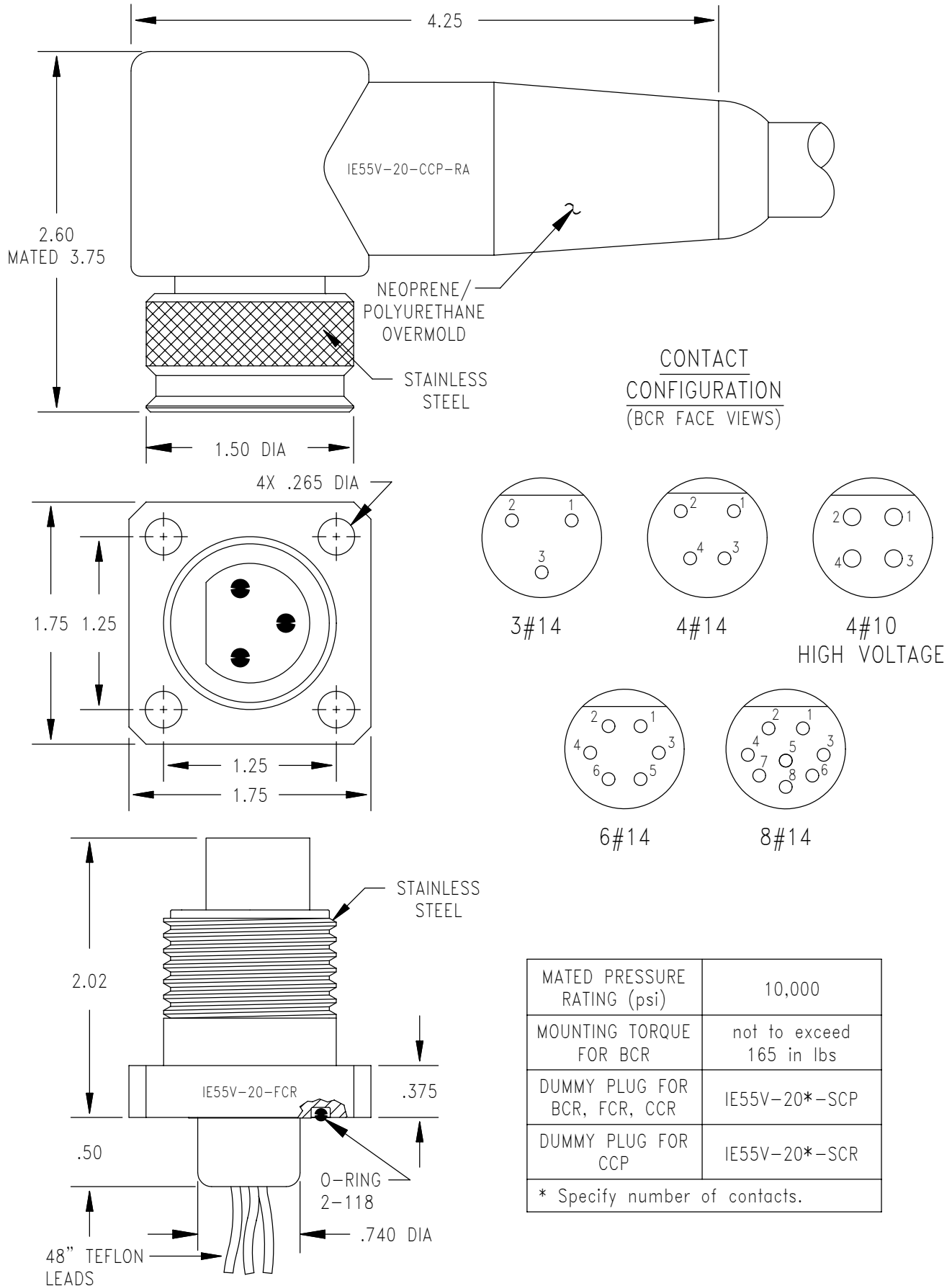

MATED PRESSURE RATING (psi)	10,000
MOUNTING TORQUE FOR BCR	not to exceed 165 in lbs
DUMMY PLUG FOR BCR, FCR, CCR	IE55V-20*-SCP
DUMMY PLUG FOR CCP	IE55V-20*-SCR
* Specify number of contacts.	