

- DESCRIPTION AND MATERIAL
- Body and engaging nut are 316 Stainless Steel, passivated per QQ-P-35 Type VI.
 - To 10,000 PSI in mated condition.
 - Bulkhead connector design open face pressure rated to 5000 PSI.
 - Contacts gold plated per MIL-G-45204.
 - Engaging nuts have Acme threads for rugged applications and for quick connection (shell size 15 has standard V thread).
 - Working voltage – 850 VDC (contact factory for high voltage applications).
- CABLE
- CCP, CCP-R/A and CCR are molded on standard 24” length of 16 AWG SO cable. IE55-1508 is molded on a standard 24” length of 18 AWG SO cable.
 - Other cable options available at customer’s request.
 - BCR/FCR have 48” teflon leads, Type E per MIL 16878/4 16 AWG.
 - Un-Terminated versions of CCP available.
- USES
- Heavy Duty applications.
 - Hazardous environment.
 - Power Transmission.
 - Signal Telemetry.
 - ROV applications.
- GUIDELINES
- All mounting and sealing surfaces require a 32 finish.
 - Lubricate mating surfaces with 3M Silicone Spray or equivalent, DO NOT GREASE! Connectors must be lubricated on a regular basis.
 - Lubricate o-rings with Dow Corning #111 Valve Lubricant or equivalent.
 - Use Dust Caps and keep connectors clean to prevent damage in storage and service.
 - Keep o-ring grooves clean and avoid cuts, nicks and tears on rubber surfaces.
 - Elastomers can be seriously degraded if exposed to direct sunlight or high ozone levels for extended periods of time.
 - Clean plugs and receptacles with soap and fresh water. Rinse out with alcohol, allowing connector to air dry.
 - Replace o-rings when re-using connectors.
- NOTE
- Also available as inverted series, see following section.
- Specifications for:
SUBMINIATURE
CONNECTOR
(Bulletin 70 03/06)
- Body and engaging nut are 6AL-4V Titanium. Engaging nut is Tiodized[®] per AMS 2488 TYPE II.
 - Working voltage – 300 VDC.
 - IE55-1204/06-CCP, CCP-R/A and CCR are molded on standard 24” 22 AWG polyurethane jacketed cable. IE55W-1002/03-CCP, CCP-R/A and CCR are molded on standard 24” 20 AWG Belden cable.
 - IE55-1204/06-BCR are molded on standard 6” Teflon lead, Type E per MIL16878/4, 24 AWG. IE55W-1002/03-BCR are molded on standard 6” Teflon lead, Type E per MIL 16878/4, 22 AWG.
 - Mainly used on small sensor packages.
 - Light duty applications only.

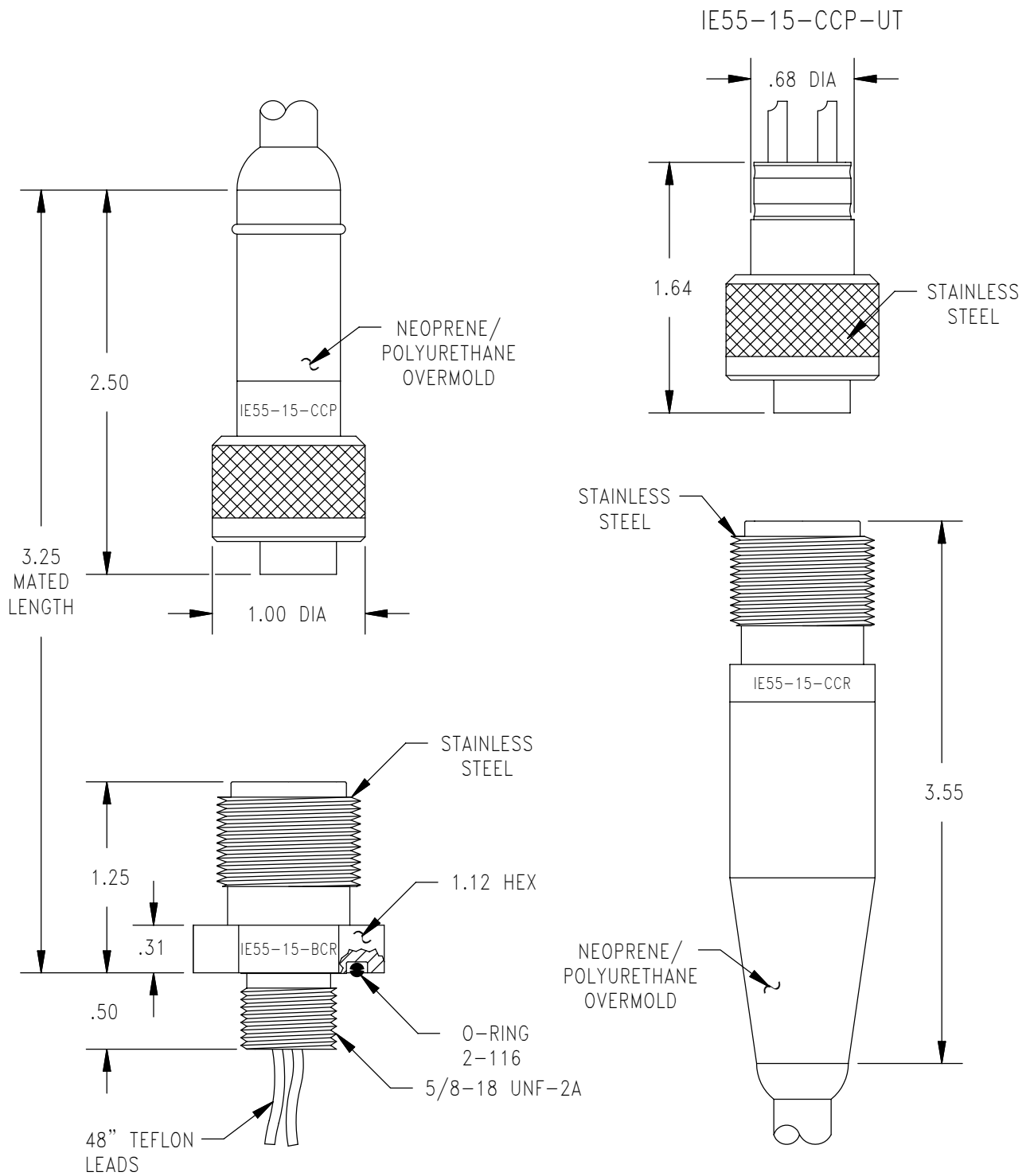

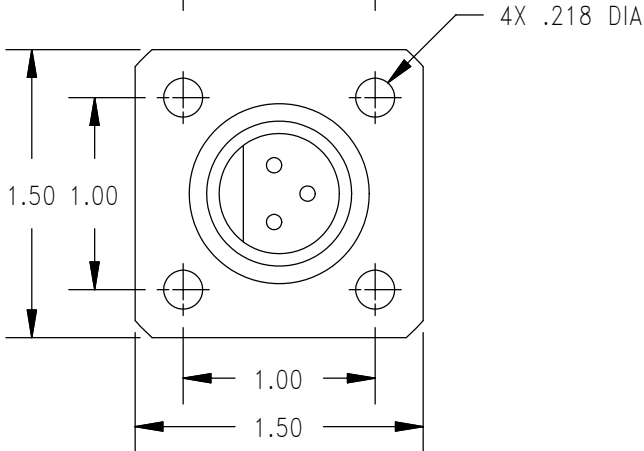

CONTACT
CONFIGURATION
(BCR FACE VIEWS)

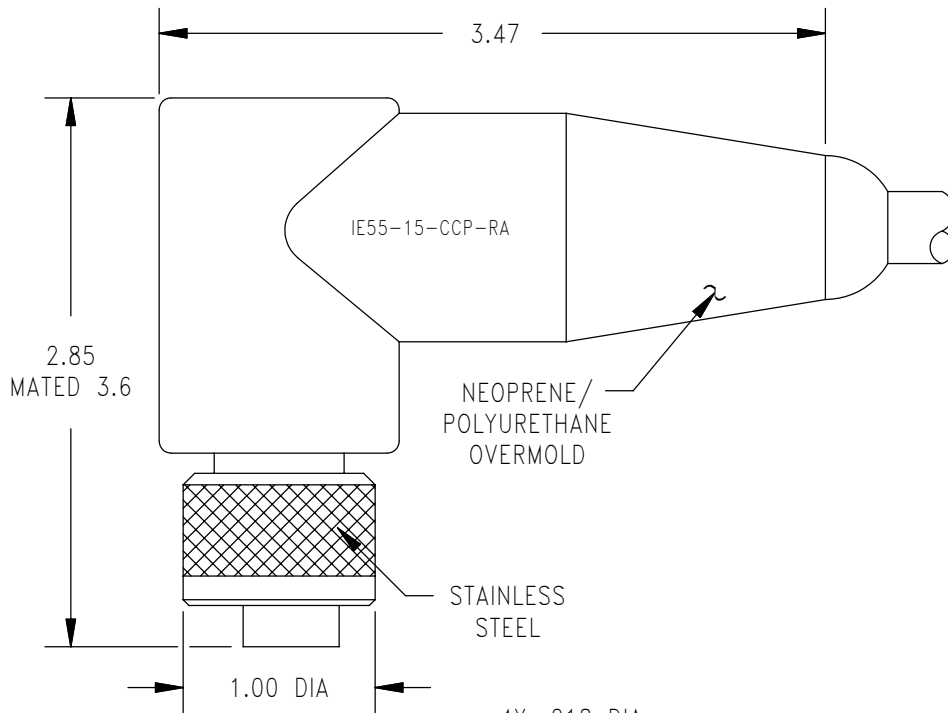
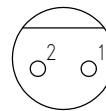

2#14

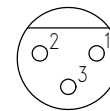

3#14

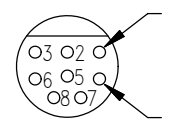

8#16

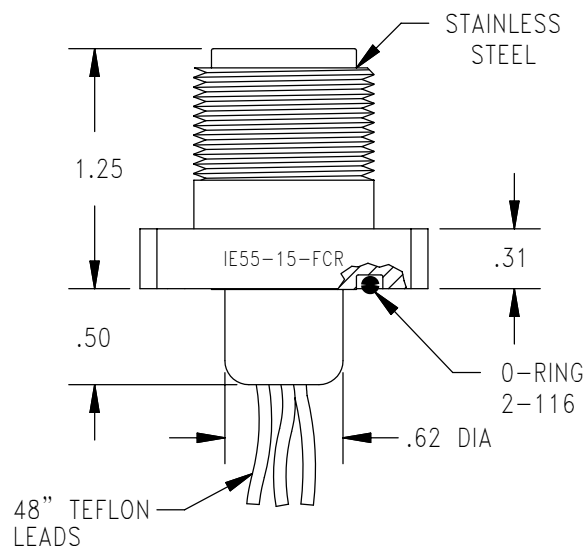

MATED PRESSURE RATING (psi)	10,000
MOUNTING TORQUE FOR BCR	not to exceed 125 in lbs
DUMMY PLUG FOR BCR, FCR, CCR	IE55-15*-SCP
DUMMY PLUG FOR CCP	IE55-15*-SCR
* Specify number of contacts.	