

---

DESCRIPTION AND MATERIAL	<ul style="list-style-type: none"><li>• 316 stainless steel passivated per QQ-P-35 Type VI with naval bronze engaging nut.</li><li>• Optional material is (MSA) 6061-T6 Aluminum, hard anodized per MIL-A-8625, Type III, Class 2.</li><li>• Special alloys are available upon request (contact factory).</li><li>• Contains a removable glass reinforced epoxy insert (with the exception of the MSSJ/MSAJ).</li><li>• One to 96 contacts.</li><li>• Up to 600 VDC. Up to 5000 VDC using high voltage insert.</li><li>• From 10,000 PSI to 20,000 PSI in mated condition (higher pressure rating available using special alloy metal shell; please contact factory).</li><li>• Bulkhead connector design open face pressure rated to 5000 psi.</li><li>• MSS-CCR/CCP connectors can be overmolded with polyurethane or neoprene.</li><li>• Conductor insulation and jacket material of specified cable determines overmold material.</li><li>• Contacts are gold plated per MIL-G-45204.</li></ul>
CABLE MATERIAL	<ul style="list-style-type: none"><li>• Connector's amperage and voltage may be limited by the amperage and voltage ratings of the cable to which the connector is molded.</li><li>• This series is not molded to cable unless specified at the time of order.</li></ul>
USES MATERIAL	<ul style="list-style-type: none"><li>• Heavy duty applications.</li><li>• Hazardous, rugged environment.</li><li>• Power transmission.</li><li>• Signal telemetry.</li><li>• FCR is mounted by use of six equally spaced bolts around the flange surface.</li><li>• FCR is used in place of the BCR when the use of a bulkhead nut and washer is impractical.</li><li>• For all open face pressures above 5,000 PSI the BCR, FCR must be back potted (please contact the factory).</li><li>• The CCR is used in a variety of rugged environments where cable to cable termination is necessary.</li></ul>
GUIDELINES MATERIAL	<ul style="list-style-type: none"><li>• Mounting torque should not exceed 200 in lbs. for this series.</li><li>• All mounting surfaces require a 32 finish.</li><li>• Align indexes.</li><li>• Keep o-ring grooves clean.</li><li>• Avoid o-ring cuts and nicks.</li><li>• Lubricate o-rings with Dow Corning #111 Valve Lubricant or equivalent.</li><li>• Replace o-rings when re-using connectors.</li><li>• Avoid contact with noxious solvents.</li><li>• Elastomers can be seriously degraded if exposed to direct sunlight or high ozone levels for extended periods of time.</li></ul>

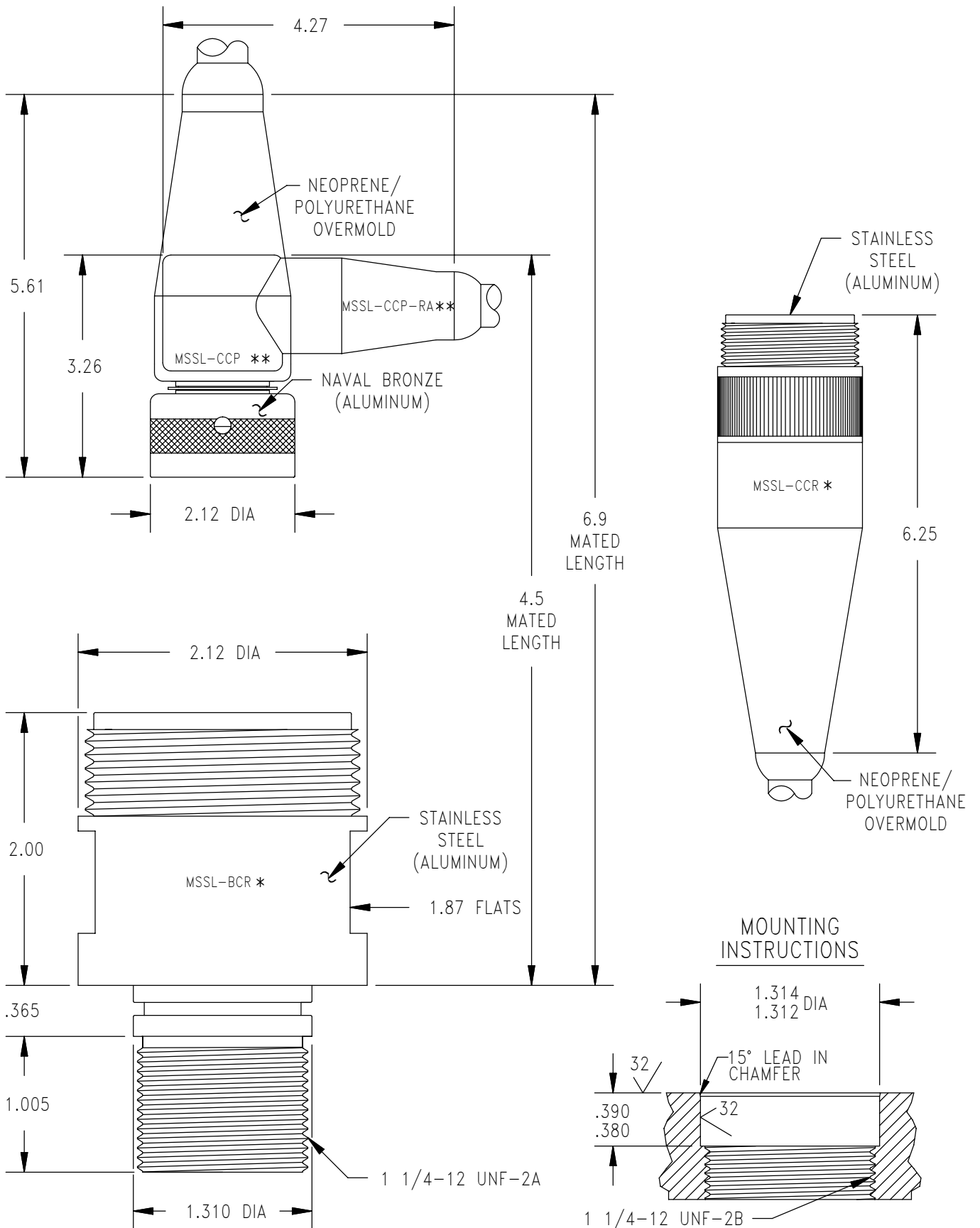

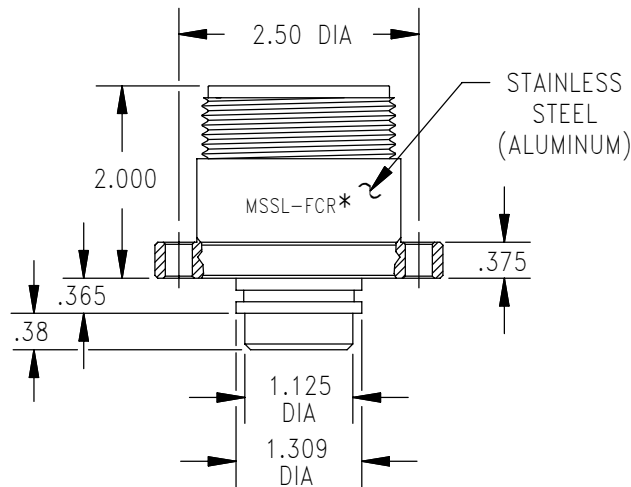
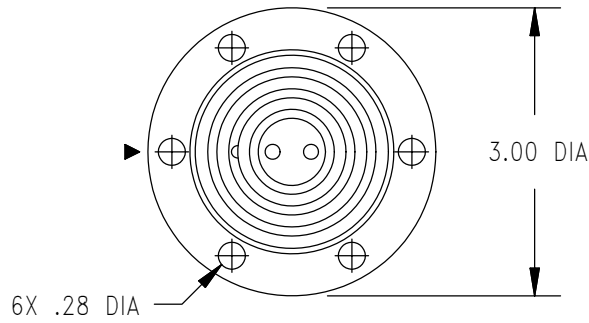

MOUNTING INSTRUCTIONS

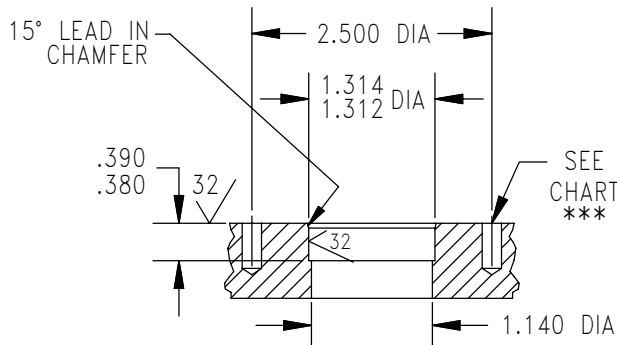

MOUNTING TORQUE FOR MSSL, MSAL-BCR	not to exceed 200 in lbs	MATED PRESSURE RATING (psi)	20,000
DUMMY PLUG FOR MSSL-BCR/FCR/CCR	MSSL-SCP	DUMMY PLUG FOR MSSL-CCP	MSSL-SCR
DUMMY PLUG FOR MSAL-BCR/FCR/CCR	MSAL-SCP	DUMMY PLUG FOR MSAL-CCP	MSAL-SCR

NOTE: Delrin protective caps available upon request.  
 \* See Technical Bulletin 45 71 for internal assembly and hardware specifications.  
 \*\* See Technical Bulletin 45 72 for internal assembly and hardware specifications.  
 \*\*\* Blind tapped hole not to penetrate bulkhead, minimum full thread depth 2 times bolt diameter.

CONTACT  
CONFIGURATION  
(BCR FACE VIEWS)

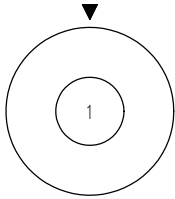

1#1/0  
1000VDC

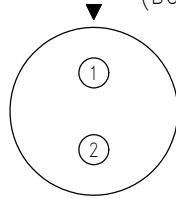

2#8  
1000VDC

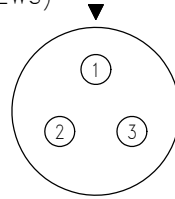

3#8  
1000VDC

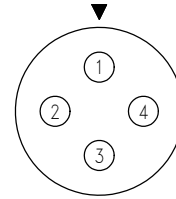

4#8\*  
1000VDC

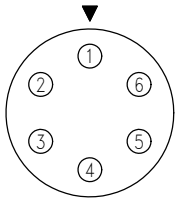

6#10  
1000VDC

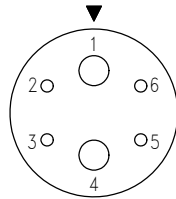

2#8  
4#16  
1000VDC

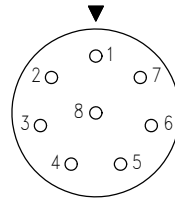

8#16  
600VDC

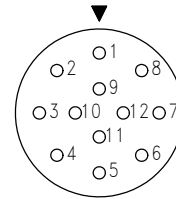

12#16  
600VDC

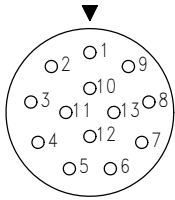

13#16  
600VDC

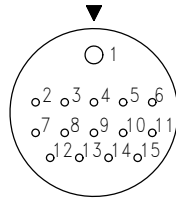

1#16  
14#20  
600VDC

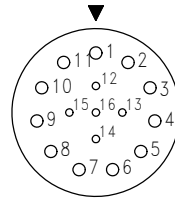

5#20  
11#16  
600VDC

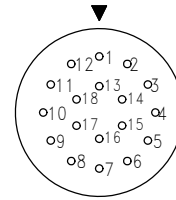

18#20  
600VDC

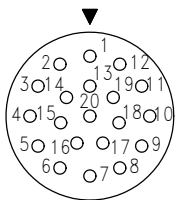

20#16  
600VDC

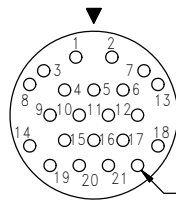

22#16  
600VDC

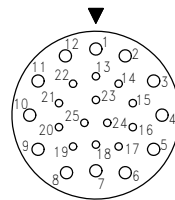

12#16  
13#20  
600VDC

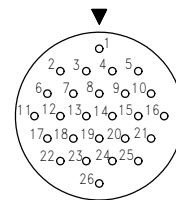

26#20  
600VDC

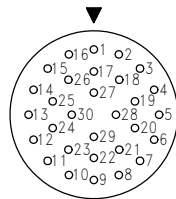

30#20  
600VDC

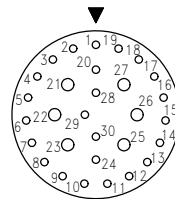

6#16  
24#20  
600VDC

\* Also available in high voltage.  
(3000VDC)