

- DESCRIPTION AND MATERIAL
- Molded glass reinforced epoxy.
 - One to 36 contacts.
 - 200 VDC to 600 VDC (higher voltage ratings available upon request).
 - Up to 20,000 PSI in mated condition.
 - Bulkhead connector design open face pressure rated to 5000 psi.
 - Contacts gold plated per MIL-G-45204.
 - XS-CCR/CCP connectors can be overmolded with polyurethane or neoprene.
 - Conductor insulation and jacket material of specified cable determines overmold material.
- CABLE
- Connector's amperage and voltage may be limited by amperage and voltage rating of cable to which connector is molded.
 - This series is not molded to cable unless specified at the time of order.
- USES
- Medium duty applications.
 - Hazardous environment.
 - Power transmission.
 - Signal telemetry.
 - CCR used in a variety of environments where cable to cable connection is necessary.
- GUIDELINES
- All mounting surfaces require a 32 finish.
 - Do not exceed mounting torque specifications.
 - Align indexes.
 - Use in areas not subject to high impact to avoid chipping and cracking.
 - Keep o-ring grooves clean.
 - Avoid o-ring cuts and nicks.
 - Lubricate o-rings with Dow Corning #111 Valve Lubricant or equivalent.
 - Replace o-rings when re-using connectors.
 - Avoid contact with noxious solvents.
 - Elastomers can be seriously degraded if exposed to direct sunlight or high ozone levels for extended periods of time.

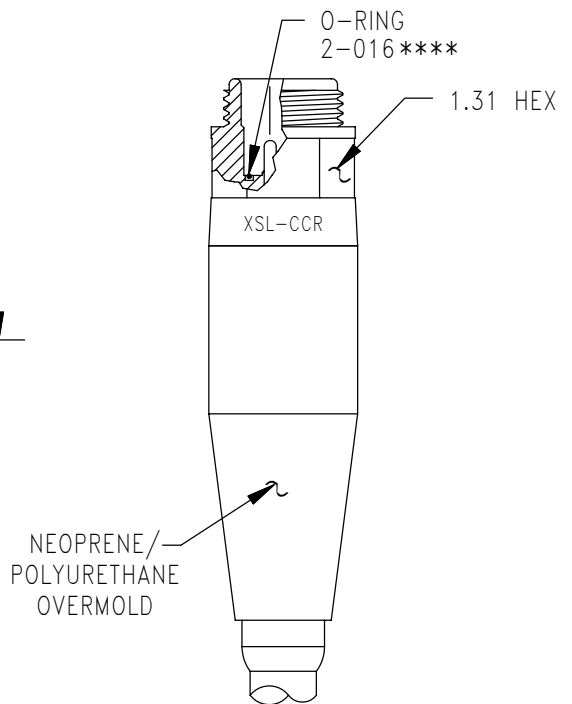

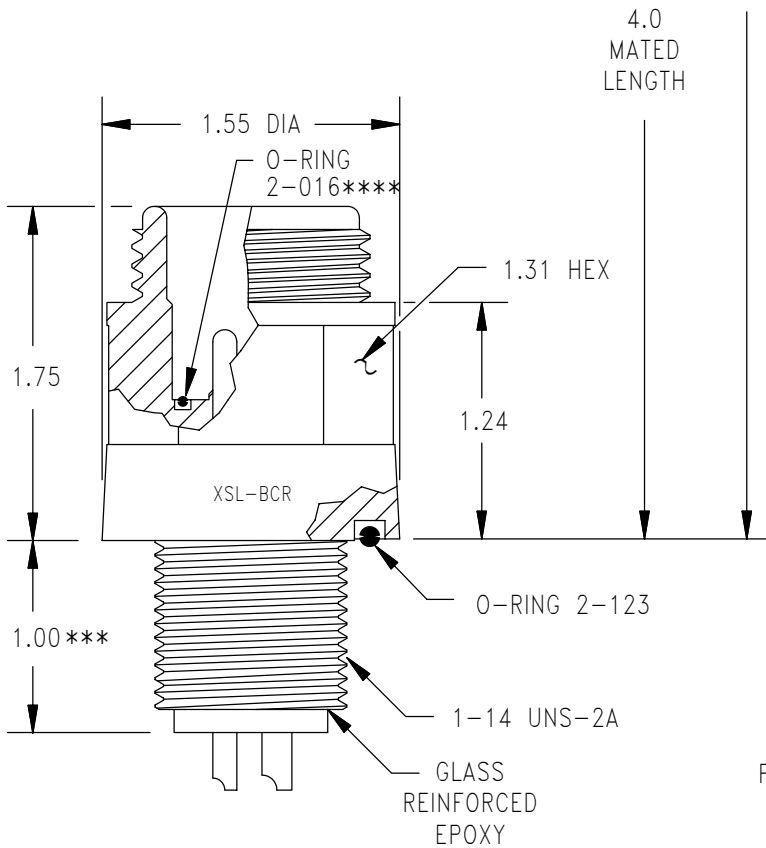
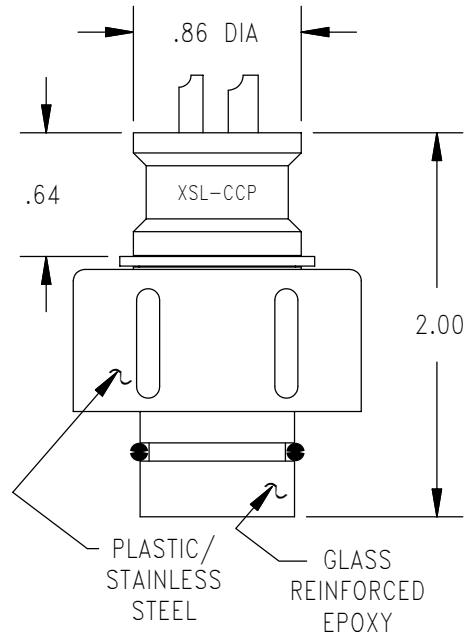
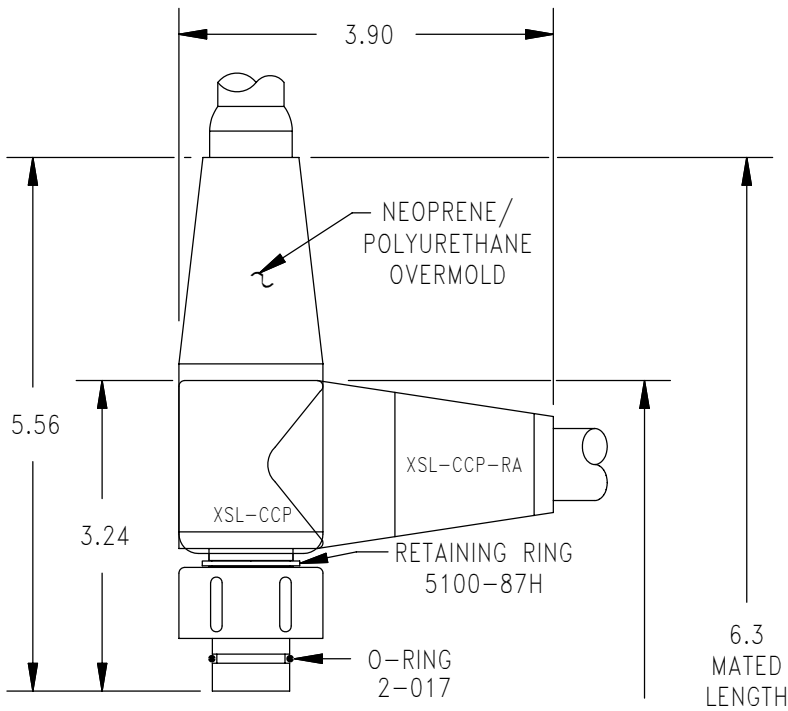
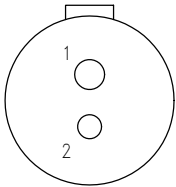
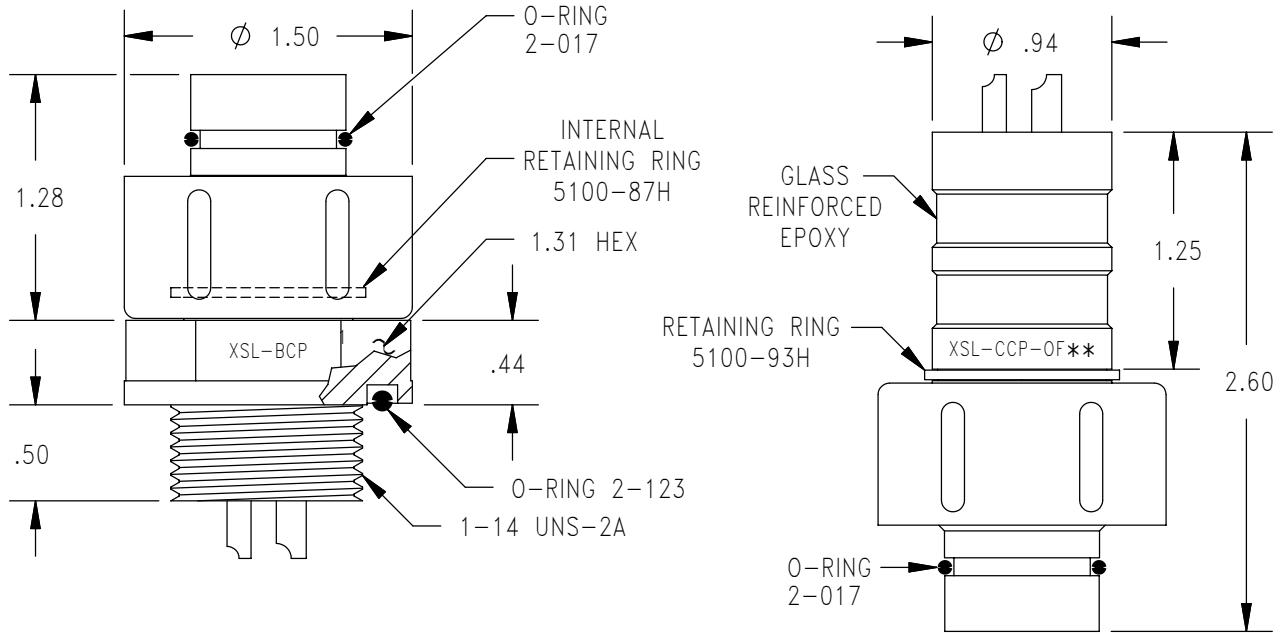

1#8/1#10
600 VDC

CONTACT CONFIGURATION
(BCR FACE VIEWS)

NOTE: Please specify narrow (.125) or wide (.250) key when ordering.

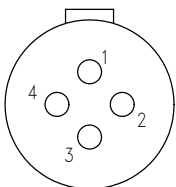

4#10
600 VDC

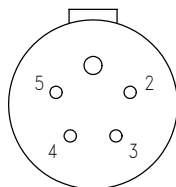

1#14/4#16
500 VDC

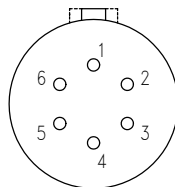

6#16
500 VDC

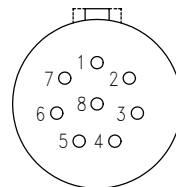

8#16
500 VDC

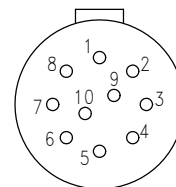

10#16
400 VDC

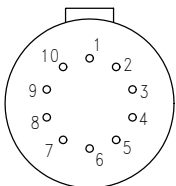

(PBOF)10#20
200 VDC

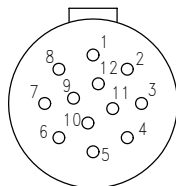

12#16
200 VDC

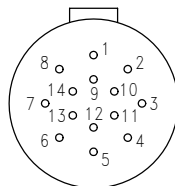

14#20
200 VDC

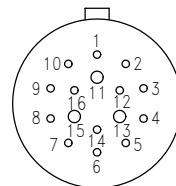

3#16/13#20
200 VDC

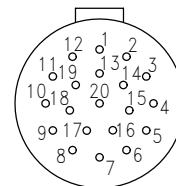

20#20
200 VDC

MOUNTING TORQUE FOR XSL-BCR/BCP	not to exceed 130 in lbs	MATED PRESSURE RATING (psi)	20,000
DUMMY PLUG FOR XSL-BCR/CCR	XSL-*--SCP	DUMMY PLUG FOR XSL-CCP/BCP/CCP/CCP-OF	XSL-*--SCR

NOTE: CCP/CCR are not terminated to cable unless specified.
 * Please specify number of contacts.
 ** Extended backshell for Oil Filled assemblies.
 *** Also available in .50 thread length, 5-12 contacts only.
 **** XSL-20-BCR, XSL-20-CCR and XSL-20-SCR use o-ring 5-254.